

Vibration Welder

Table Size 38" (965mm) by 18" (455mm)



FEATURES

- Electromechanical vibration head assembly (200-240Hz)
- Super rigid four rail table slide system
- Massive flame cut bridge
- Solid state 15hp digital vibration drive
- Hydraulic lift/clamp force max. 4500 lbs. (20,000 N), 20 gallon reservoir, (75.6 L)
- Allen-Bradley® SLC 5/03 controller with two available expansion slots
- Allen-Bradley Panel View 600 full color touch screen display
- Intuitive and interactive comprehensive help menu
- Part parameter monitoring with programmable limits
- Choice of either English or Spanish menu structure
- Automatic tuning
- Programmable amplitude 0.040" to 0.070" (1.0 to 1.8 mm)
- Weld by time and weld by distance (absolute or meltdown)
- Interior work light
- Optical zero force cycle activation switches
- Light Curtain for single switch activation
- Less than 80 db in operation (continuous measurement)
- Dual external utility outlets

SPECIFICATIONS

- Table size 38" x 18" (965 x 455mm) (also max. tool size*)
- Table opening 24" by 10" (610 x 250mm) with max., depth 20" (500mm) except F/B center strip 3" (75mm) wide with depth of 1/2" (12mm)**
- Upper tool weight 35-90 pounds (15-40kg)
- Low 41" (1040mm) lift table height
- 20" (500mm) Stroke, 25" (630mm) Max daylight

OPTIONS

- Position adjustable cycle activation switches
- Exterior work light
- Customer-specified PLC and interface
- Custom paint per customer specification
- Rear sliding door for pass-through operation
- Programmable pneumatic clamp or eject valves and/or programmable part-in-place sensing
- We can also quote machines with custom frame sizes, lift tables, stroke lengths, etc., using standard vibration heads

* Tool can in some instances overhang the back of the table by a modest amount. Consult Dukane for more information.

** Custom lift table or custom frame can be quoted to allow for an uninterrupted "bucket" for greater depth.

www.dukcorp.com/us • e-mail: ussales@dukcorp.com

Vibration Welder Model VWB3500 Floor Layout

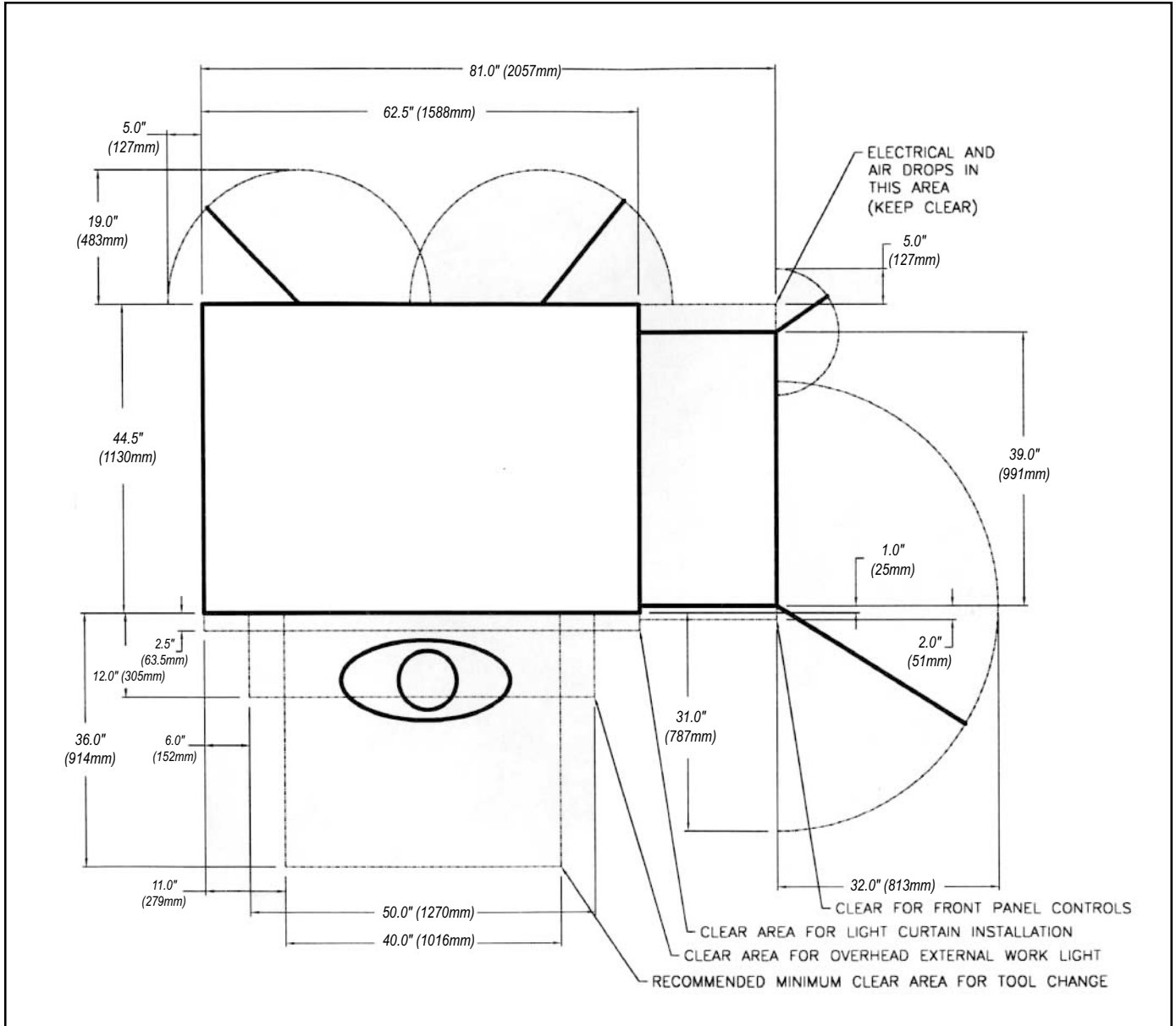

Note: All specifications are subject to change without notice. Please consult Dukane Ultrasonics for any updated information.

Electric Service Required: 480V, 3 Phase, 30 Amps (custom input voltage kits available)

Pneumatic Service Required: 75 to 90PSI (5-6 Bar)